

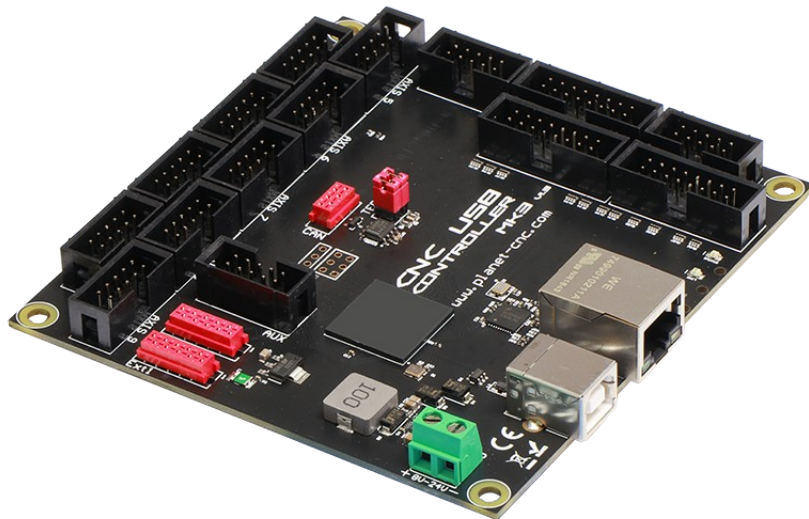

CNC USB Controller Mk3

User manual

2022-04-25



Disclaimer

CONTROLLER AND CONTROLLER SOFTWARE ARE PROVIDED TO YOU "AS IS," WITHOUT WARRANTY. THERE IS NO WARRANTY FOR THE CONTROLLER AND CONTROLLER SOFTWARE, EITHER EXPRESSED OR IMPLIED, INCLUDING, BUT NOT LIMITED TO, THE IMPLIED WARRANTIES OF MERCHANTABILITY AND FITNESS FOR A PARTICULAR PURPOSE AND NONINFRINGEMENT OF THIRD PARTY RIGHTS. THE ENTIRE RISK AS TO THE QUALITY AND PERFORMANCE OF THE CONTROLLER OR CONTROLLER SOFTWARE IS WITH YOU. SHOULD THE CONTROLLER OR CONTROLLER SOFTWARE PROVE DEFECTIVE, YOU ASSUME THE COST OF ALL NECESSARY SERVICING, REPAIR OR CORRECTION.

IN NO EVENT SHALL THE AUTHOR BE LIABLE TO YOU FOR DAMAGES, INCLUDING ANY GENERAL, SPECIAL, INCIDENTAL OR CONSEQUENTIAL DAMAGES ARISING OUT OF THE USE OR INABILITY TO USE THE CONTROLLER OR CONTROLLER SOFTWARE.

1 Introduction

1.1 Overview

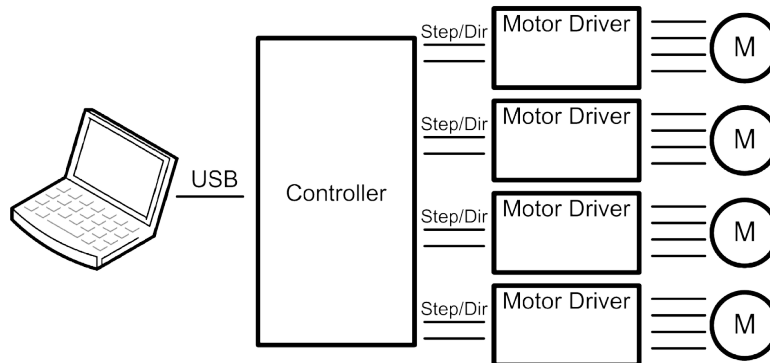

PlanetCNC hardware:

PlanetCNC series of USB CNC motion controllers serve as a link between a personal computer and motor drivers that support step/direction control. PlanetCNC series of motion controllers are compatible with most motor drivers. Controllers use the USB or Ethernet port, available on all modern computers and laptops.

PlanetCNC motion controllers can serve as direct replacement or upgrade for many parallel port break-out boards.

PlanetCNC software:

PlanetCNC motion control system provides a complete, fully integrated software/hardware solution. Additional machine control software is NOT required. The *PlanetCNC TNG* motion control software is a dedicated application, designed to fully exploit the features of the purpose-built hardware. It has many advanced features to assist day-to-day CNC machine operation.

PLEASE NOTE:

PlanetCNC controllers are compatible only with PlanetCNC motion control software and vice versa.

1.2 Features and specifications:

1.2.1 PlanetCNC TNG motion control software

- works with PC/Laptop running :
 - Windows 7,8 or 8.1, 10, 11 (32 bit or 64bit)
 - Linux 64-bit OS
 - Intel based iMAC with High Sierra or newer OS
- Raspberry Pi 3 and Pi4 running Raspbian
- advanced interpolation algorithms for smoother motion and toolpath optimization
- standard RS274/NGC G-code
- advanced G-codes - G40, G41, G42 (Cutter Radius Compensation) supported
- advanced G-codes - G43, G49 (Tool Length Offsets) supported
- advanced G-codes - G54, G59.3 (Coordinate System Origins) supported
- tested with SolidCAM, MasterCAM, ArtCAM, SheetCAM, Vectric, DeskProto, CamBam, MeshCAM, LightBurn ... generated G-code
- Profili2 and DevFoam 4-axes and 3-axes G-code for foam-cutting supported
- import toolpath from DXF files
- import toolpath from PLT/HPGL files
- import toolpath from SVG files
- import toolpath from image files
- import toolpath from CSV files
- import toolpath from NC-Drill (Excellon) files
- import toolpath from Gerber (RS-274X) files
- export toolpath to G-code
- export toolpath to DXF
- export toolpath to CSV
- automatic homing procedure
- multiple languages supported
- import of language files supported
- built-in support for manual and automatic toolchange procedure
- import of backup machine profile supported
- export of backup machine profile supported
- multiple view of toolpath supported
- built-in manual gcode editor supported
- gcode program line bookmarking supported
- gcode program line search tool supported
- MDI command history supported
- Transformation of gcode program supported (Transformation from points)
- Gcode program manipulation tools supported (Shift, Scale, Mirror, Rotate...)
- Warp supported (curved surface compensation)
- Copy and swap tools for XYZ, UVW axes supported
- Machine Start, Stop, Pause, Estop control supported
- Start from selected program line supported
- Start from beginning to bookmark supported
- Start from bookmark to bookmark supported

- Start from bookmark to end supported
- gcode program loop execution supported
- Mist control supported
- Flood control supported
- Spindle CW, CCW control supported
- digital outputs control supported
- axis motor enable control supported
- soft limits supported
- hard limits supported
- probe trigger for simulation purposes supported
- tool table with integrated feed&speed calculator supported
- tool length measurement supported
- G28 and G30 home positions supported
- unwind tool for ABC rotational axes supported
- work position measure height supported
- coordinate systems supported
- coordinate systems edit table supported
- built in machining cycles supported
- probe measure procedures supported (inside, outside corner, edge, edge angle, hole center, slot, protrusion measurement)
- point measurement supported
- camera supported
- user commands supported
- gcode scripts for flexible machine behavior supported
- Expression file advanced functions supported
- USB file for advanced USB communication of external equipment supported
- Python scripts for advanced external processes supported
- backlash compensation
- customization of GUI supported
- SDK (software developers kit) available

1.2.2 Mk3 - 9 axes USB CNC controller

- USB and Ethernet connection
- 9 STEP & DIRECTION axis outputs for stepper and servo motors
- 110 kHz maximum step frequency, configurable minimum pulse width, 50% duty cycle at higher frequencies
- 8 digital outputs on board (3 digital outputs configurable as:TTL, frequency, PWM or RC servo motors signal outputs)
- additional outputs with ExtInOut boards available(currently up to 32)
- jogging keyboard supported
 - Speed potentiometer, shift, step and ALT features are supported
- 8 limit switch inputs with shift feature (buffered for maximum performance)
- 8 digital inputs
 - Buffered for maximum performance
 - Tool length sensor configuration supported
 - Movable sensor configuration supported
 - Measure probe configuration supported
- additional inputs with ExtInOut boards available(currently up to 32)
- 4 analog inputs
- Wireless MPG pendant support
- Dedicated Inputs for spindle encoder and index signals for spindle synchronization (buffered for maximum performance)
- I2C protocol interface supported
- UART protocol interface supported
- SSP protocol interface supported
- CAN interface (currently in development)

1.3 System Requirements

Minimum system requirements:

- 1 GHz or faster processor
- 512MB RAM
- 500 MB available hard disk space
- Graphics with OpenGL support
- USB 2.0 port
- .NET Framework 3.5 SP1

Recommended system requirements:

- 2 GHz or faster processor
- 2GB RAM
- 500 MB available hard disk space
- Graphics with OpenGL support
- USB 2.0 port
- .NET Framework 3.5 SP1

2 Hardware

2.1 Installation



Installation of PlanetCNC CNC USB Controller requires a USB equipped PC or laptop along with motor drivers appropriate to the motors in use. The USB CNC controller is compatible with the vast majority of motor drivers that use step/direction signals.

Optional support hardware can be employed to customize installation to suit user requirement. Use of a screw terminal adapter makes connection to the type of drive in the image much easier. A DB25 adapter is available, for motor drivers requiring this form of input, with male or female DB25 connector.

For maximum flexibility in controller layout, a ribbon cable and plug kit is available. This aids the construction of longer cables and ensures plug-in connections correspond to the USB CNC Controller pin outs.

IMPORTANT:

The controller should be powered with an external power supply.
Mk3 - 9 Axis controller hardware requires 8 - 24V DC supply
Power supply should be at least 200mA.

2.2 Mk3 - 9 axis CNC USB controller description

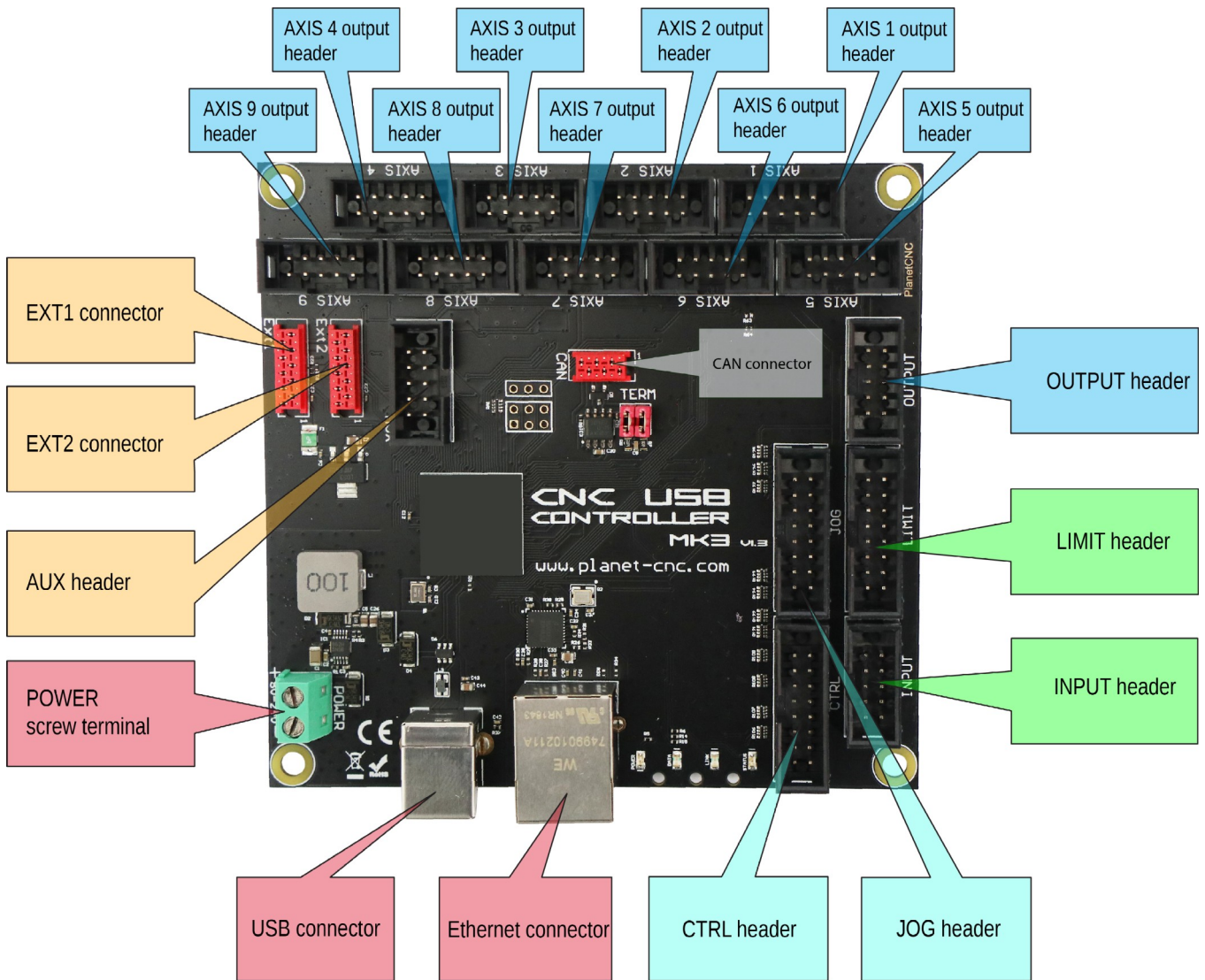

2.2.1 Mk3 AXIS connector

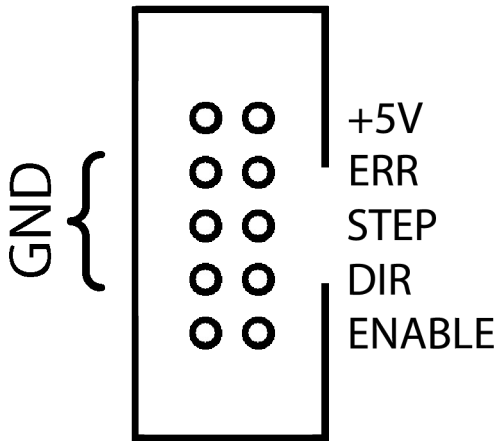

Each connector controls one motor driver. Controller has 9 connectors for axes 1-9. This means 9 axes which can all be moved at same time.

Axes are usually named like this: Axis 1=X, Axis 2=Y, Axis 3=Z...

On some machines this can be different. For example Foam cutter uses axis names such as Axis 1=A, Axis 2=Y, Axis 3=U, Axis 4=V. Lathes use Axis 1=Z, Axis 2=X. Configuration of axes, as well as their naming can be set in *File/Settings/Axes*.

CONNECTOR PIN DESCRIPTION:

+5V: +5V power. Motor drivers can take power for logic circuit or common anode connection from the USB controller.

ERR: Error signal from driver to controller.

STEP: Provides a STEP signal of minimum 25 us pulse width or 50% duty cycle at higher frequencies to the motor driver.

DIR: Provides DIR or DIRECTION signal to the motor driver.

ENABLE: Provides an ENABLE signal for motor drivers. When the ENABLE signal is lost, due to output command, E-Stop or limit switch activation, motor drivers will deactivate.

A dedicated E-Stop switch connected to the CTRL or INPUT connector can control the signal. It can also be operated by limit switch activation, software command or on shutdown of the control software.

This arrangement provides a useful safety feature that can be user-configured to operate under manual and/or computer control.

GND: Ground connections.

2.2.2 Mk3 JOG connector

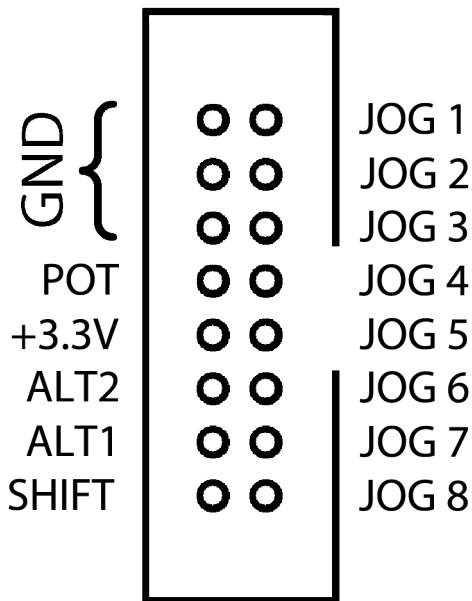

Switched operation of JOG 1-8 controls manual jogging.

Jogging keyboards can use a 'SHIFT' key, allowing Mk3 controller users to jog additional axes or toggle the option of jog 'step' mode. 'SHIFT' key function is defined in settings, as is the 'step' value for each key press.

Jogging keyboards can use two 'ALT' keys. Function is defined in 'settings'.

Jogging directions and axis assignment can be defined in 'settings'.

CONNECTOR PIN DESCRIPTION:

A typical use might be as below.

JOG 1:	Jog Axis 1 in negative direction.
JOG 2:	Jog Axis 1 in positive direction.
JOG 3:	Jog Axis 2 in negative direction.
JOG 4:	Jog Axis 2 in positive direction.
JOG 5:	Jog Axis 3 in negative direction.
JOG 6:	Jog Axis 3 in positive direction.
JOG 7:	Jog Axis 4 in negative direction.
JOG 8:	Jog Axis 4 in positive direction.
SHIFT:	Jogging for additional axes or selects 'step' jog mode.
ALT1:	Selects different jog mode
ALT2:	Selects different jog mode
+3.3V:	Power for jogging speed POT
POT:	Jogging speed POT
GND:	Ground connections

2.2.3 Mk3 *LIMIT* connector

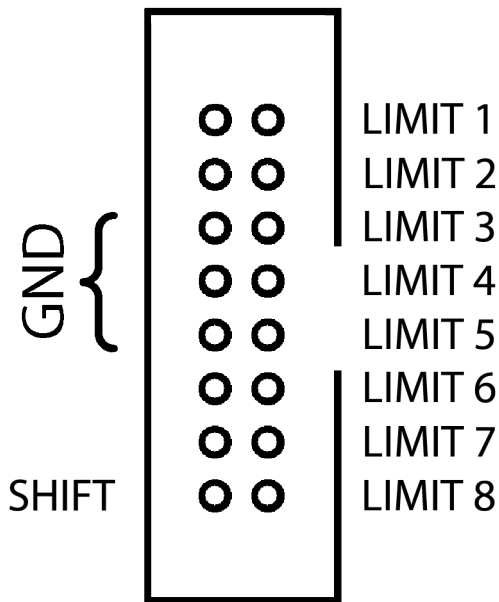

LIMIT 1-8 connects limit switches. It's recommended that a 100nF capacitor is connected directly across switch terminals.

The 'SHIFT' key toggles limit options using one of two possible configurations. The chosen configuration determines hardware connections.

Limit switches can be connected in 'Normal' method or 'Single input' method. In software, you can set this in *File/Settings/Limit*. If you are using 'Normal' method, 'Single Input' feature must be disabled.

To pause all axes, if certain axes limit switch has been activated, you enable 'Lock Other Axes'.

NORMAL: Each switch is connected to its own pin.

- LIMIT 1:** Axis 1 negative limit
- LIMIT 2:** Axis 1 positive limit
- LIMIT 3:** Axis 2 negative limit
- LIMIT 4:** Axis 2 positive limit
- LIMIT 5:** Axis 3 negative limit
- LIMIT 6:** Axis 3 positive limit
- LIMIT 7:** Axis 4 negative limit
- LIMIT 8:** Axis 4 positive limit
- SHIFT:** Toggle Limit switch options
- GND:** Ground connections

SHIFT OFF: Axes 1 to 4 limits are selected

SHIFT ON: Axes 5 to 8 limits are selected

SINGLE INPUT: Both axis limit switches are connected to one pin.

Direction of travel determines if positive or negative switch is triggered.

LIMIT 1:	Axis 1 negative and positive limit
LIMIT 2:	Axis 2 negative and positive limit
LIMIT 3:	Axis 3 negative and positive limit
LIMIT 4:	Axis 4 negative and positive limit
LIMIT 5:	Axis 5 negative and positive limit
LIMIT 6:	Axis 6 negative and positive limit
LIMIT 7:	Axis 7 negative and positive limit
LIMIT 8:	Axis 8 negative and positive limit
SHIFT:	Axis 9 negative and positive limit
GND:	Ground connections

NOTE: If 'normally open' (NO) type switches are used, wiring must be done in parallel method, if 'normally closed' (NC) type switches are used, wiring must be done in serial method.

Software 'Invert' options allow use of 'normally closed' or 'normally open' switch hardware. This feature can be set in *File/Settings/Limit/Invert*

2.2.4 Mk3 CTRL connector

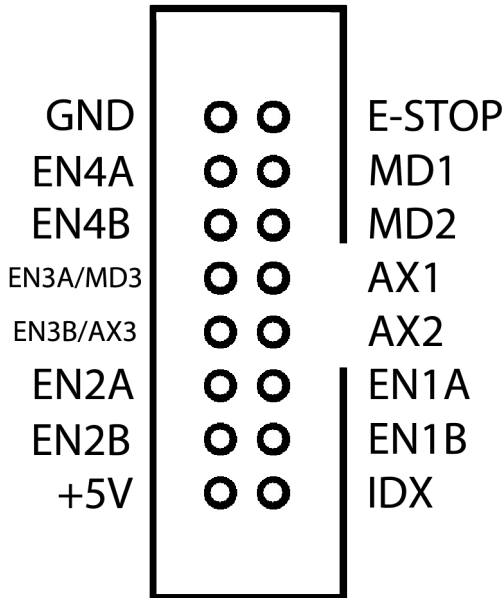

This connector provides inputs for use of MPG pendant devices and E-Stop. Spindle speed encoder for spindle synchronization can also be connected. GND pin provides 'Ground' or common connections.

An E-Stop switch attached to this connector can be configured in software to activate/deactivate E-Stop.

E-Stop switch hardware for use with this connector can be NC (Normally Closed) or NO (Normally Open). If NC is used, 'Invert' feature must be enabled in 'settings'. Locking switch is recommended.

CONNECTOR PIN DESCRIPTION:

E-STOP:	E-Stop
MD1:	Mode switch
MD2:	Mode switch
AX1:	Axis switch
AX2:	Axis switch
EN1A:	Encoder for MPG
EN1B:	Encoder for MPG
IDX:	Index signal for spindle synchronization
+5V:	Power supply for encoder
EN2B:	Additional encoder
EN2A:	Additional encoder
EN3B/AX3:	Axis switch for additional axes or encoder
EN3A/MD3:	Mode switch or encoder
EN4B:	Encoder for spindle synchronization
EN4A:	Encoder for spindle synchronization
GND:	Ground

Axis switch logic table:

Axis 1: AX1 pin activated

Axis 2: AX2 pin activated

Axis 3: AX1 pin and AX2 pin activated

Axis 4: AX1 pin and AX3 pin activated

Axis 5: AX2 pin and AX3 pin activated

Axis 6: AX1,AX2 pins and AX3 pin activated

Mode switch logic table:

Mode 1: MD1 pin activated

Mode 2: MD2 pin activated

Mode 3: MD1 pin and MD2 pin activated

Mode 4: MD1 pin and MD3 pin activated

Mode 5: MD2 pin and MD3 activated

Mode 6: MD1, MD2 pins and MD3 pin activated

2.2.5 Mk3 *INPUT* connector

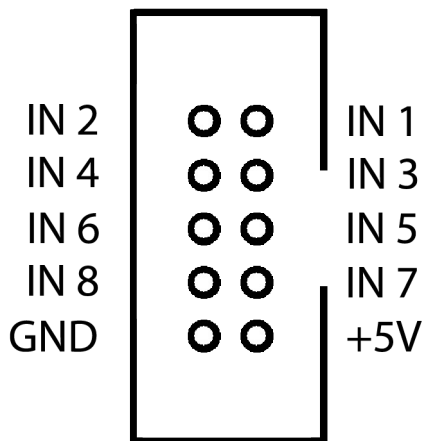

This connector provides input for user-assigned functions.

CONNECTOR PIN DESCRIPTION:

INPUT1:	Assignable input 1
INPUT2:	Assignable input 2
INPUT3:	Assignable input 3
INPUT4:	Assignable input 4
INPUT5:	Assignable input 5
INPUT6:	Assignable input 6
INPUT7:	Assignable input 7
INPUT8:	Assignable input 8
+5V:	Power supply
GND:	Ground

2.2.6 Mk3 *OUTPUT* connector

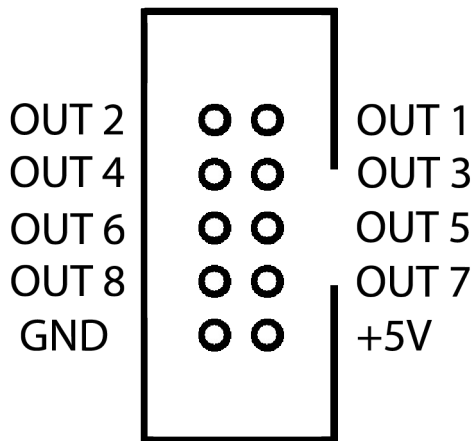

This connector provides 7 digital outputs for control of external devices. The optional 'Output board' links to the Mk3 controller using this connector. Output assignment is controlled in software.

CONNECTOR PIN DESCRIPTION:

OUT 1 - 8: Digital Output

GND: Ground

+5V: +5V supply.

OUT 1, 2 and 6 can generate PWM signal, RC servo signal or frequency modulation.

2.2.7 Mk3 EXT1 connector

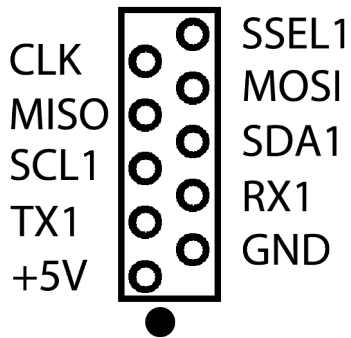

This connector allows use of EX, I2C and UART protocol devices.

CLK:	EXT CLK signal
MISO:	EXT MISO signal
SCL1:	I2C 1 SCL signal
TX1:	UART 1 TX signal
+5V:	+5.0V supply
SSEL1:	EXT 1 SSEL signal
MOSI:	EXT MOSI signal
SDA1:	I2C 1 SDA signal
RX1:	UART 1 RX signal
GND:	Ground

2.2.8 Mk3 EXT2 connector

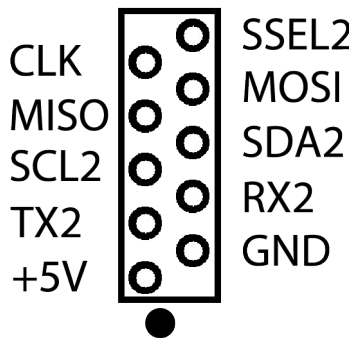

This connector allows use of EXT, I2C and UART protocol devices.

CLK:	EXT CLK signal
MISO:	EXT MISO signal
SCL2:	I2C 2 SCL signal
TX2:	UART 2 TX signal
+5V:	+5.0V supply
SSEL2:	EXT 2 SSEL signal
MOSI:	EXT MOSI signal
SDA2:	I2C 2 SDA signal
RX2:	UART 2 RX signal
GND:	Ground

2.2.9 Mk3 CAN connector

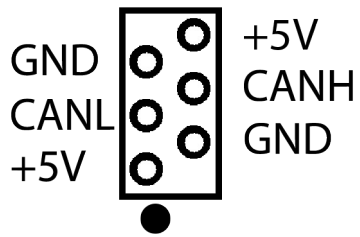

This connector allows use of CAN protocol devices.

PLEASE NOTE: CAN INTERFACE IS CURRENTLY UNDER DEVELOPMENT

GND: Ground
CANL: CANL CAN signal
+5V: +5.0V supply

+5V: +5.0V supply
CANH: CANH CAN signal
GND: Ground

2.2.10 Mk3 AUX connector

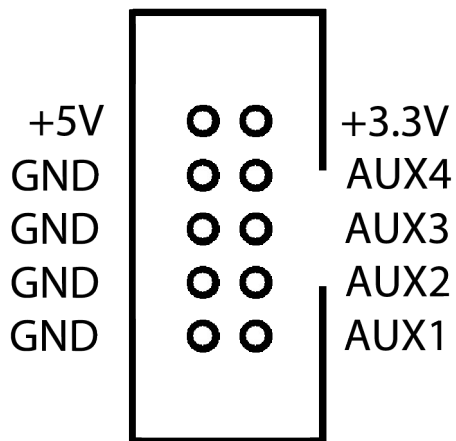

PLEASE NOTE: Input pins on this header are not filtered and buffered.

AUX1:	Auxiliary analog/digital input pin
AUX2:	Auxiliary analog/digital input pin
AUX3:	Auxiliary analog/digital input pin
AUX4:	Auxiliary analog/digital input pin
+3.3V:	+3.3V supply
+5V:	+5.0V supply
GND:	Ground connections

2.2.11 Mk3 POT connector

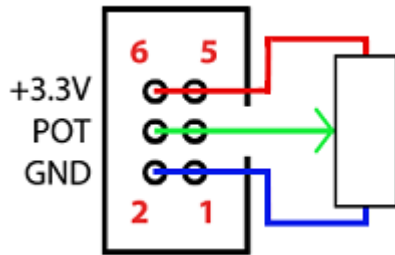

A potentiometer attached to this connector provides a manual jog speed control when using jogging keyboard connected to JOG connector. Mk3 controller also has this pins on jogging connector.

+3.3V: +3.3V power supply for use with potentiometers.

POT: 5k or 10k ohm, logarithmic taper potentiometer can be connected to provide a jog speed control.

GND: Ground

2.2.12 Mk3 *USB* connector

The Mk3 USB CNC controller connects to computer via the USB port. The port uses the USB 2.x standard.

2.2.13 Mk3 *Ethernet* connector

The Mk3 USB CNC controller connects to computers via the Ethernet port.

2.2.14 Mk3 *Power* terminal

The controller should be powered with an external power supply.
Mk3 - 9 Axis controller hardware requires 8 - 24V DC supply
Power supply should be at least 200mA.

2.2.15 Mk3 *LED* indicators

The user is provided with helpful feedback and live 'status' information via on-board LED indicators. There are four indicators.

- POWER:** Lights when the controller is powered.
- DATA:** Indicates controller functions.
- LINK:** Indicates controller communication.
- STATUS:** Blinks to indicate controller function is 'good'.

3 Connection diagrams

3.1 Wiring of limit switches

Mk3 controller has 8 designated limit switch inputs. In software you can set which wiring method is used. You can use 'Normal' or 'Single Input' method of wiring.

- When 'Normal' method is used, each axis limit switch has its designated limit pin.
- When 'Single input' method is used both limit switches are connected to one limit pin.

Since Mk3 controller does not have screw type connector mounted on the board, you can use Planet-CNC 16-pin adapter which comes in great help when wiring limit switches:

Pin description of 16-pin adapter board when connected to Mk3 Limit connector:

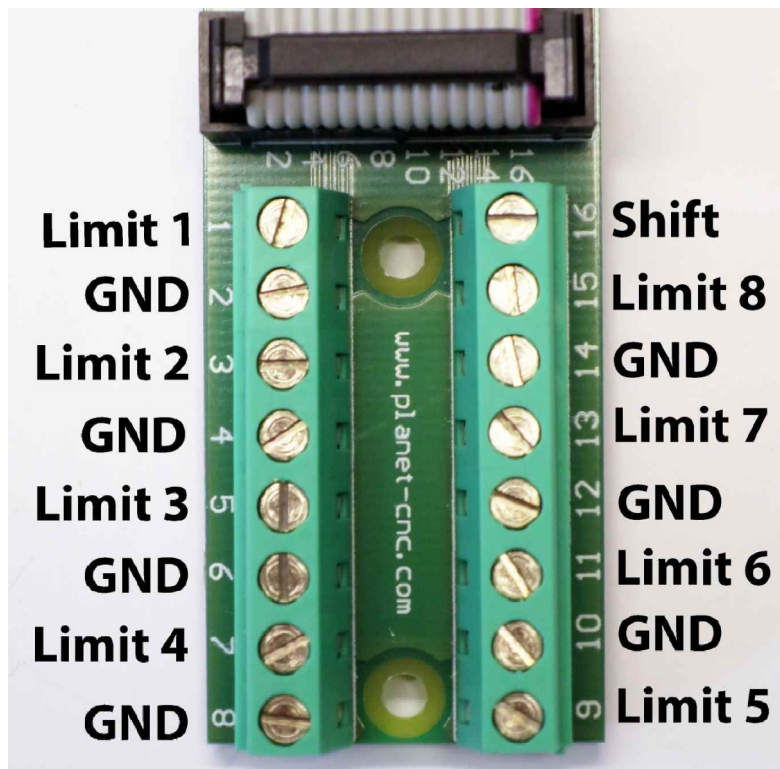

Bellow are wiring plans and pictures that demonstrate wiring of limit switches when 'Normal' or 'Single input' method is used.

3.1.1 'Normal' wiring method

NO or NC type switches can be used. When NC type switches are used, 'Invert Limit' function must be enabled in software.

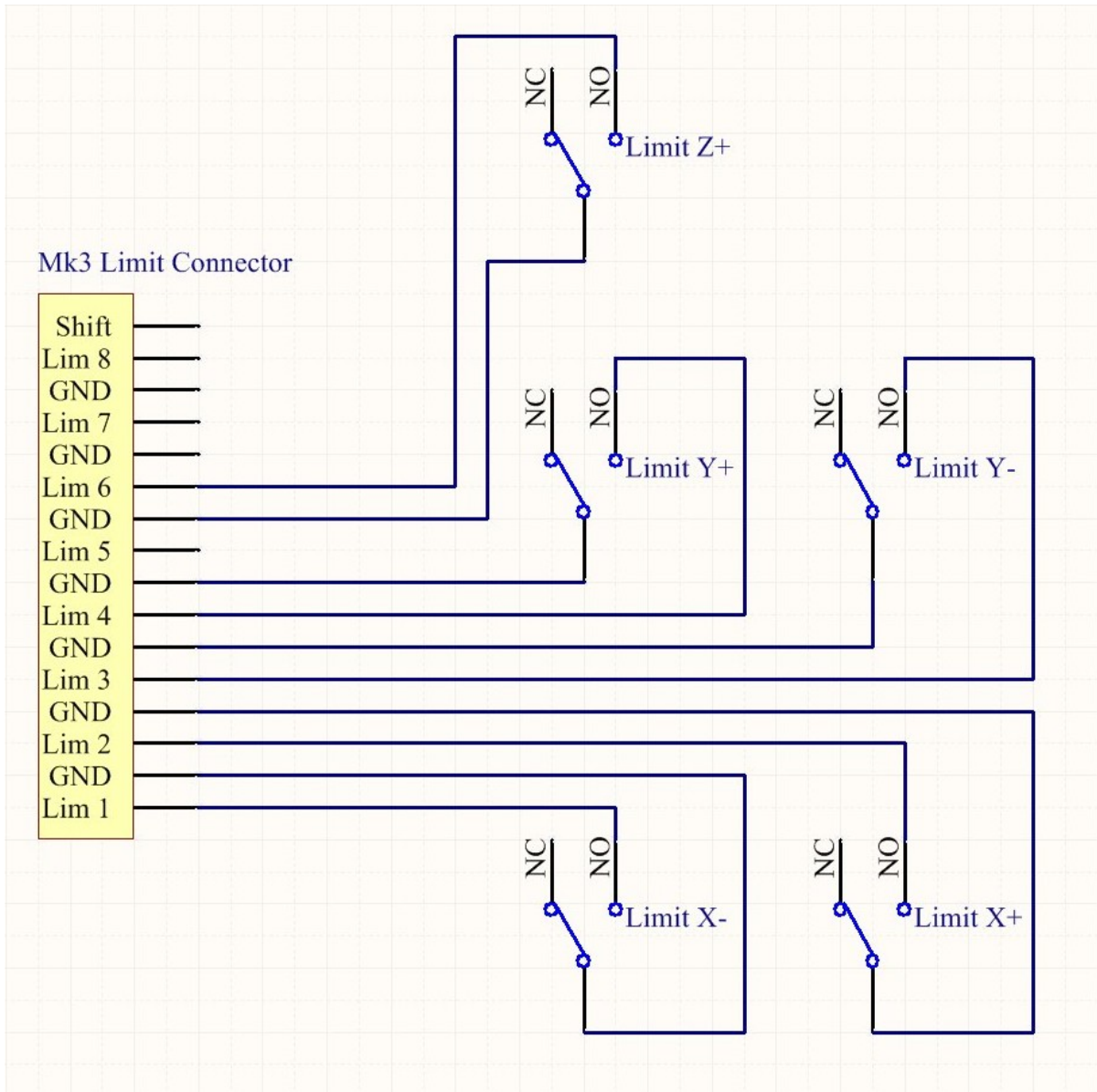

Each limit switch is connected to its own limit input pin.

'Normal' wiring method of limit switches* using Planet-CNC 16-pin adapter board:

Normal input

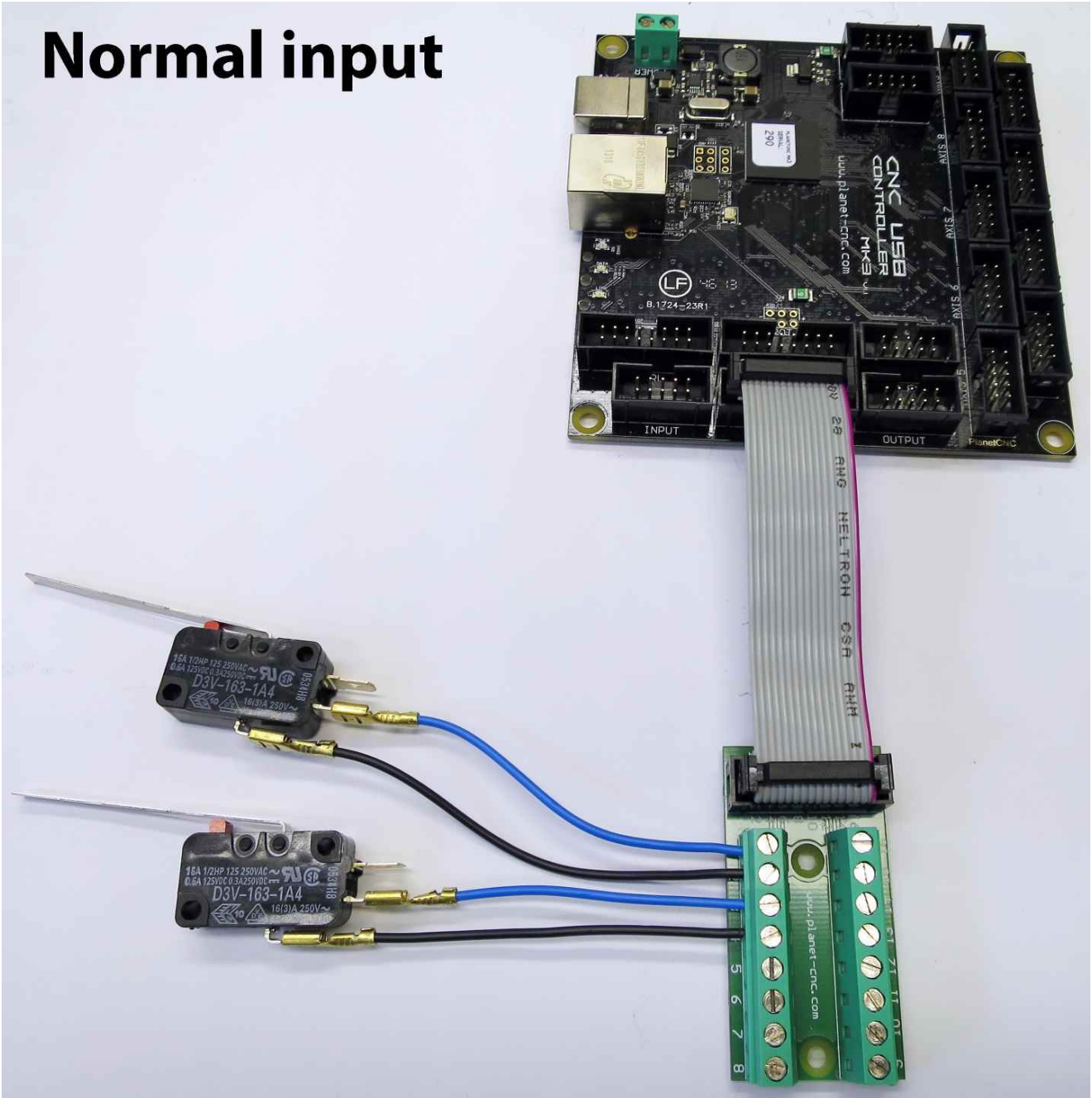

*On this picture only for axis one.

3.1.2 'Single input' wiring method

3.1.2.1 Parallel wiring of NO type switches:

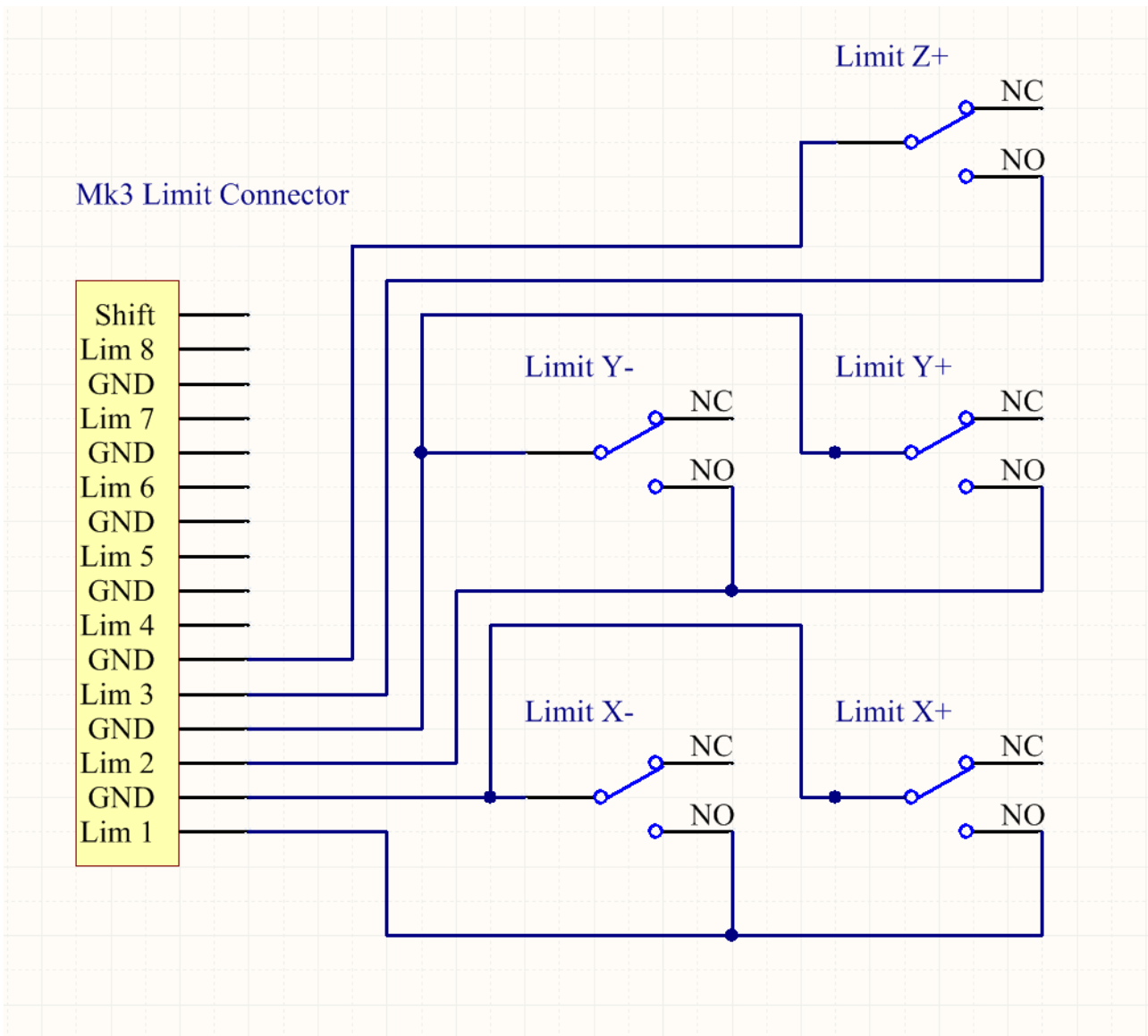

Parallel wiring of NO type limit switches* using Planet-CNC 16-pin adapter board:

Single input: Parallel method (NO switches)

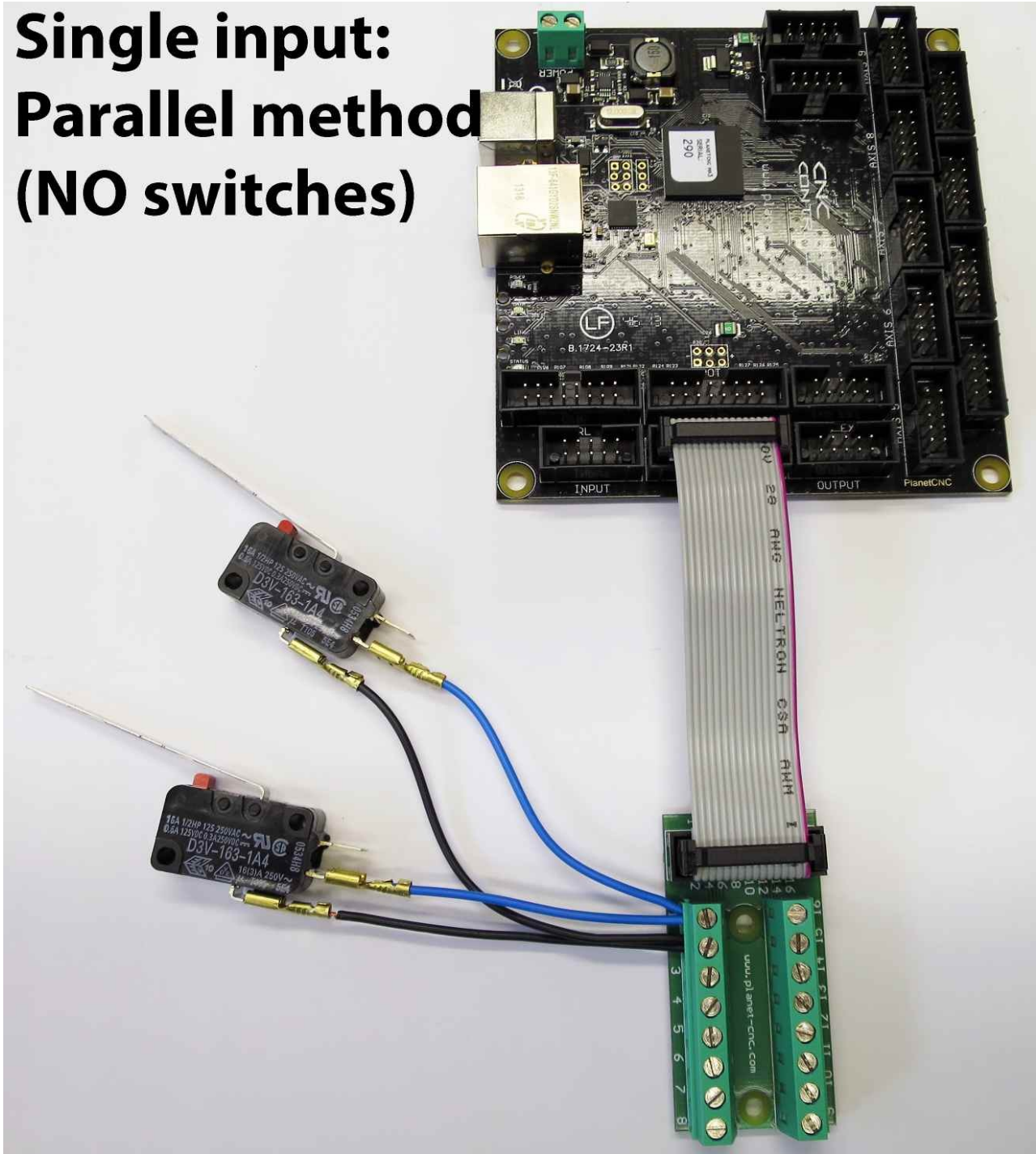

* On this picture only for axis one.

3.1.2.2 Serial wiring of NC type limit switches:

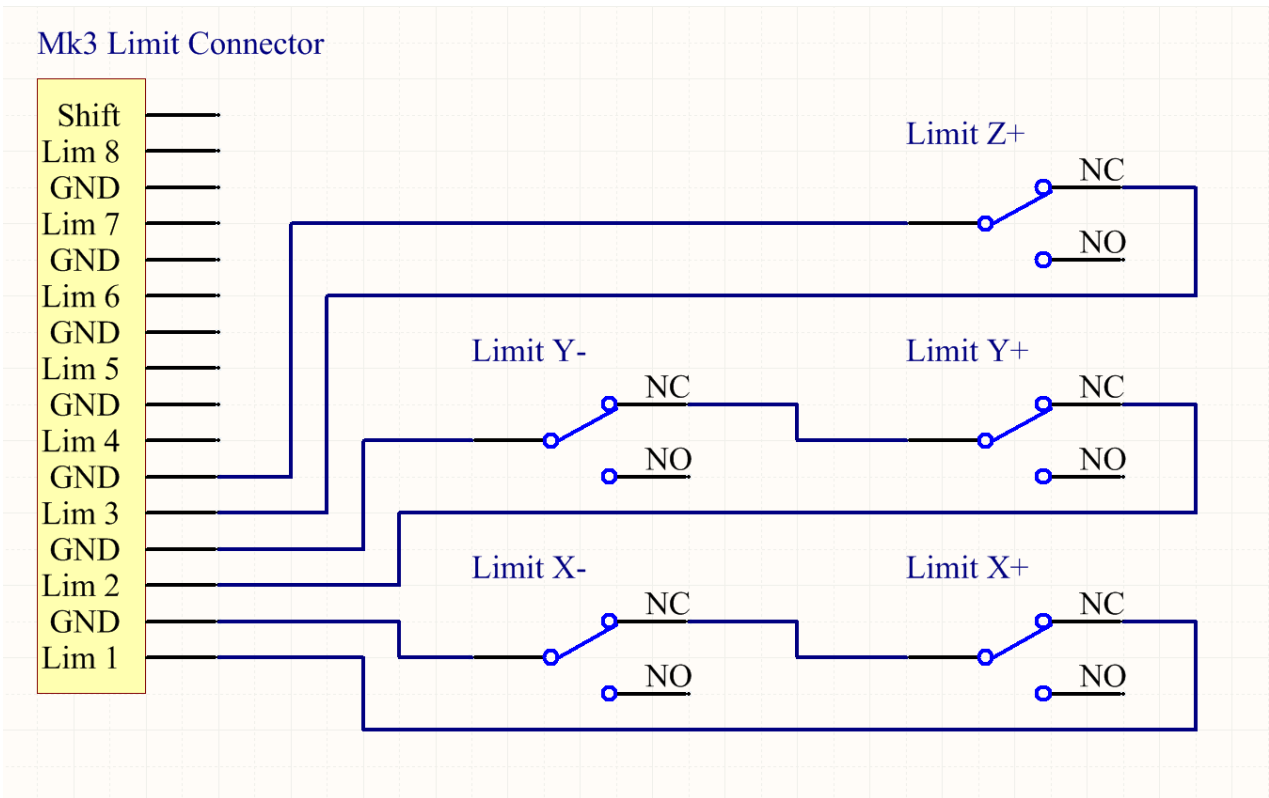

Serial wiring of NC type limit switches* using Planet-CNC 16-pin adapter board:

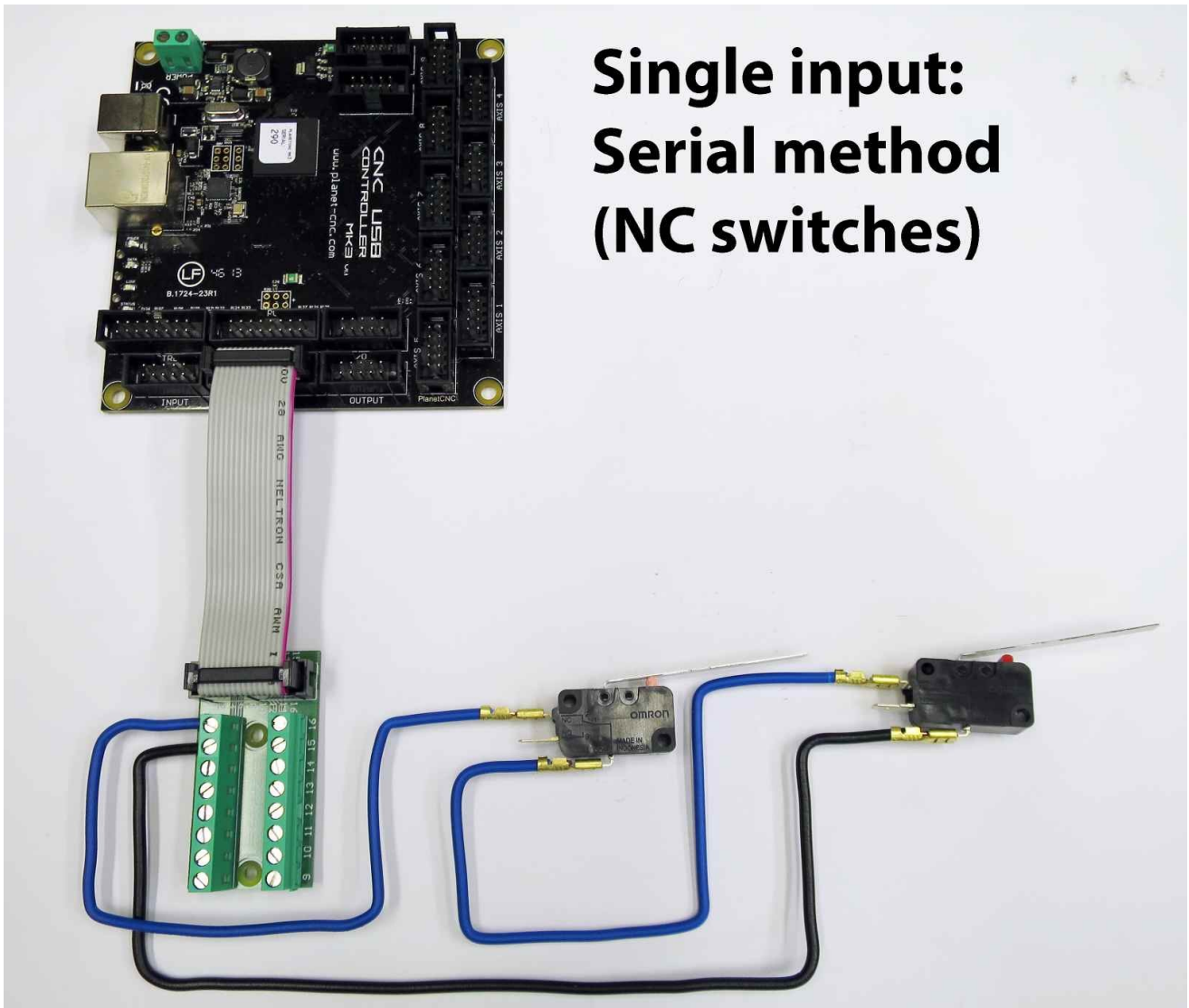

*On this picture only for axis one.

3.2 Wiring inputs of Mk3 controller

Mk3 has eight assignable inputs. Bellow is wiring diagram and picture of connected tool sensor to Mk3 controller using Planet-CNC 10-pin adapter board.

Pin description of 10-pin adapter board when connected to Mk3 Input connector:

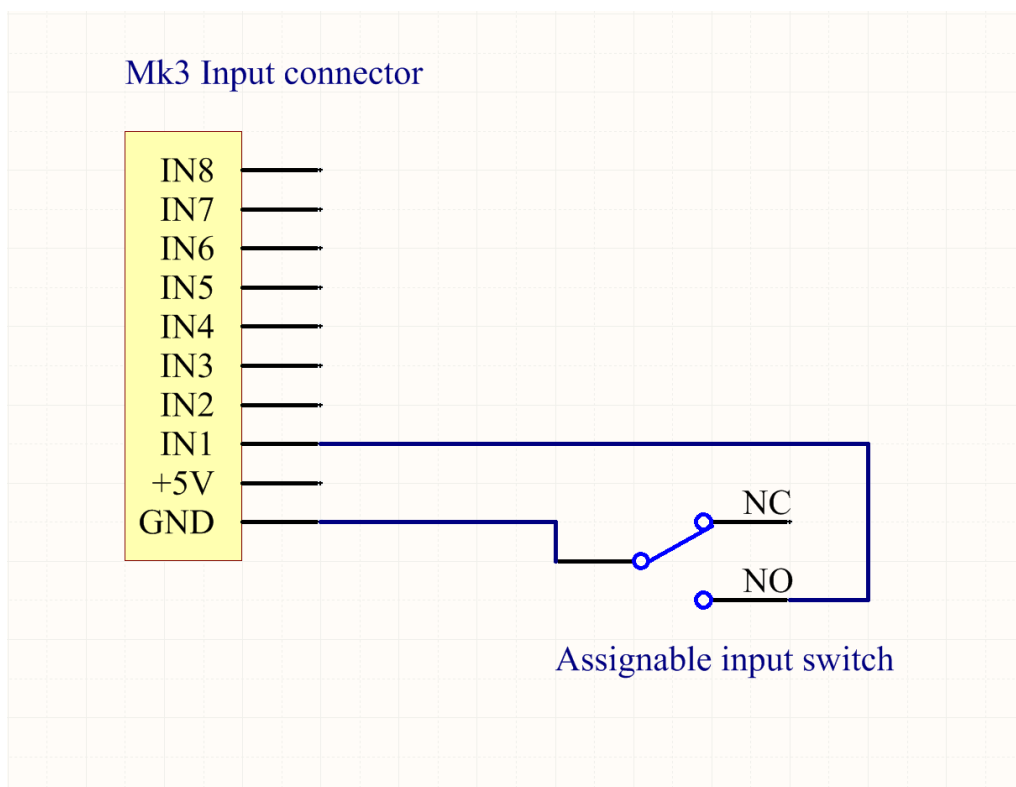
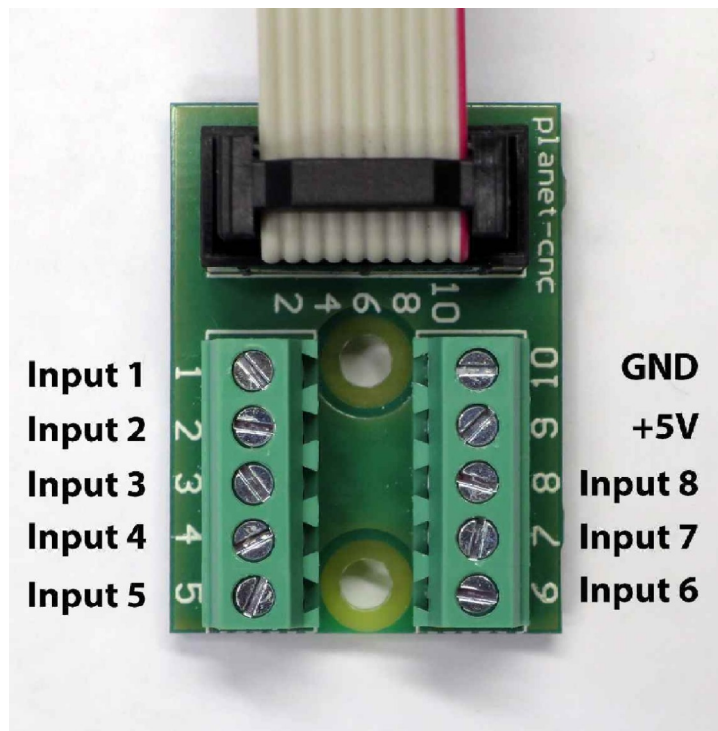

Example: Connecting tool sensor to input 5 of Mk3 input connector:

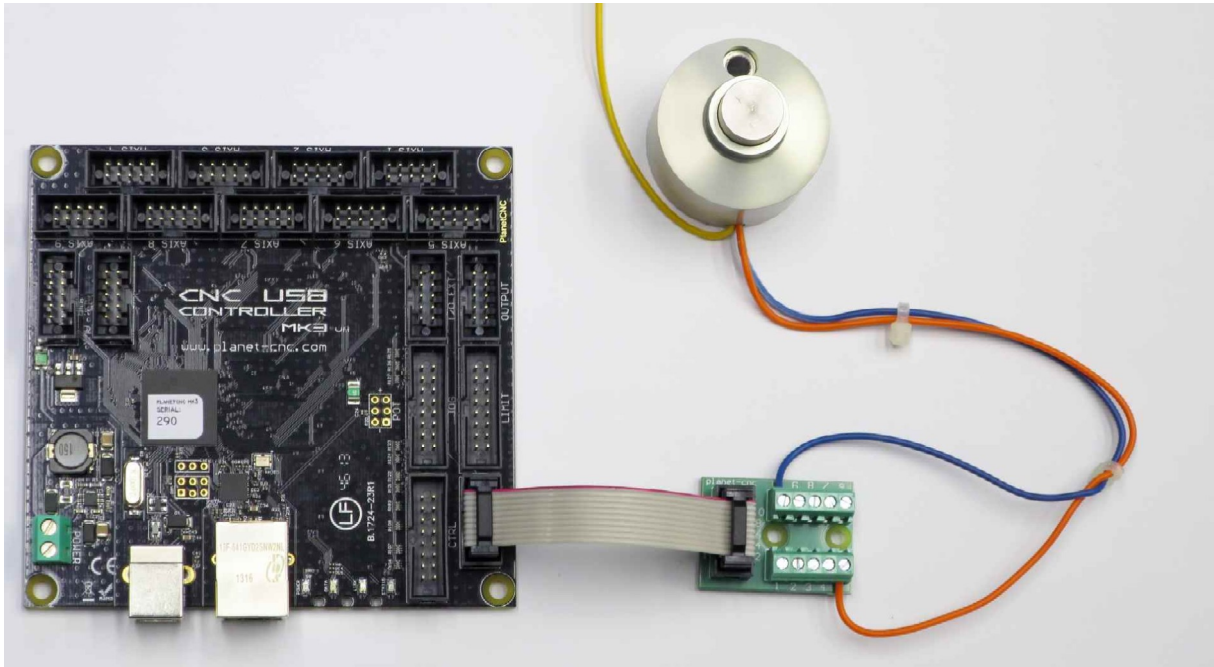

3.3 Connecting motor driver to Mk3 controller

Wiring diagrams for COMMON CATHODE and COMMON ANODE connection of motor driver:

COMMON CATHODE

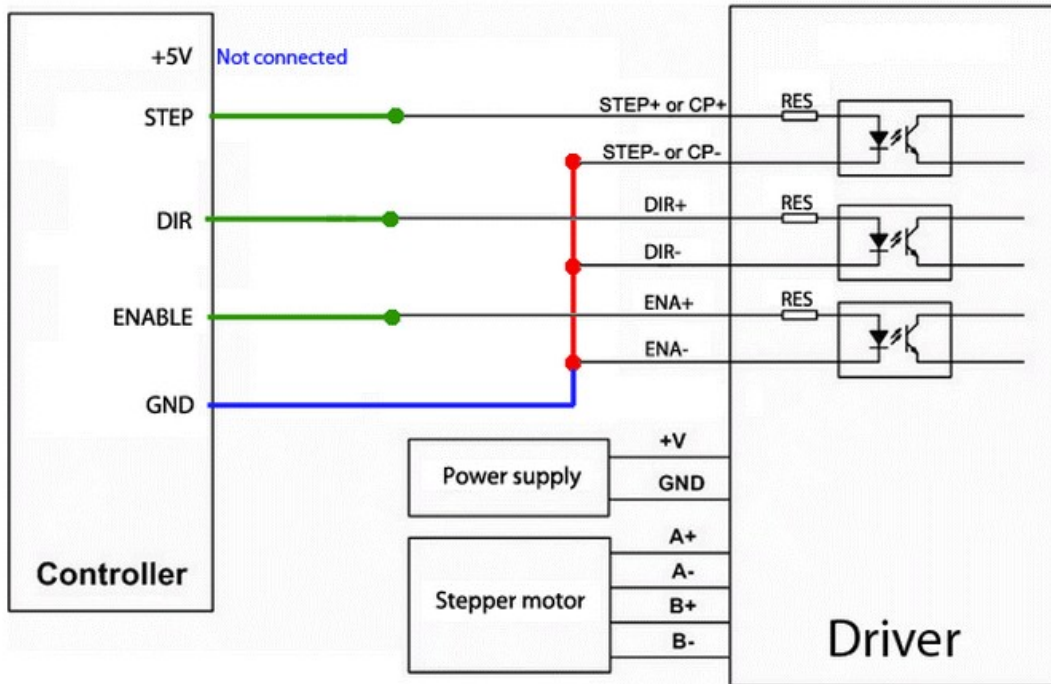

2. Common anode

COMMON ANODE

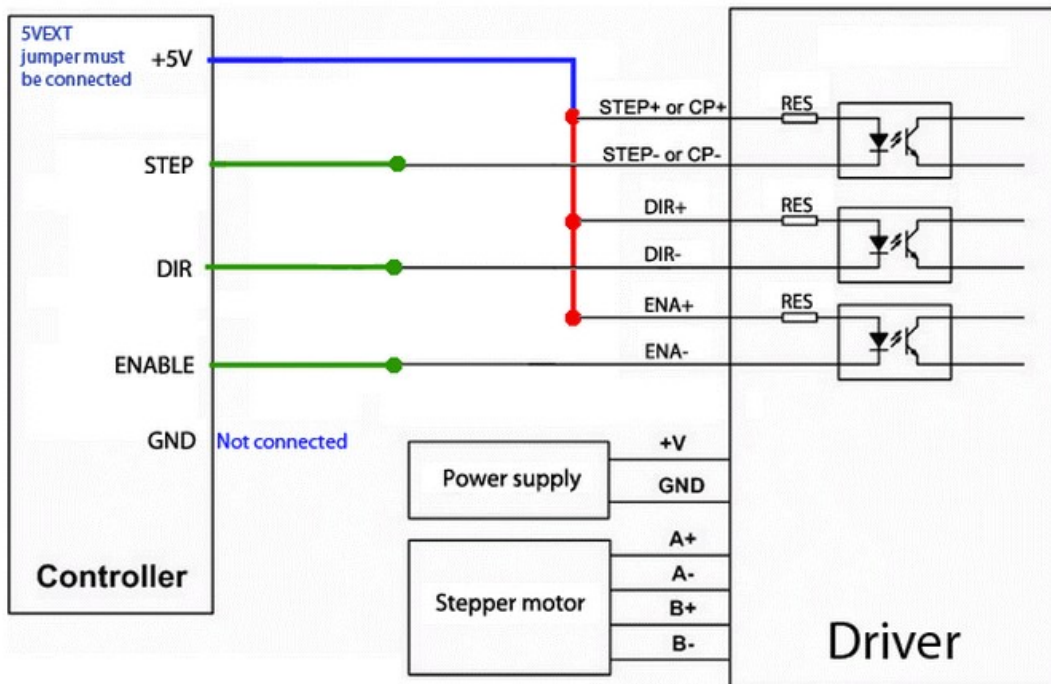

*STEP input on motor drivers can be also labeled as PUL or CLK.

Picture bellow demonstrates the connection of 2.5A Motor driver to Mk2 controller and connection of stepper motor and power supply to 2.5A motor driver. Since this motor driver uses 10-pin header and ribbon cable, connection is pretty much trivial:

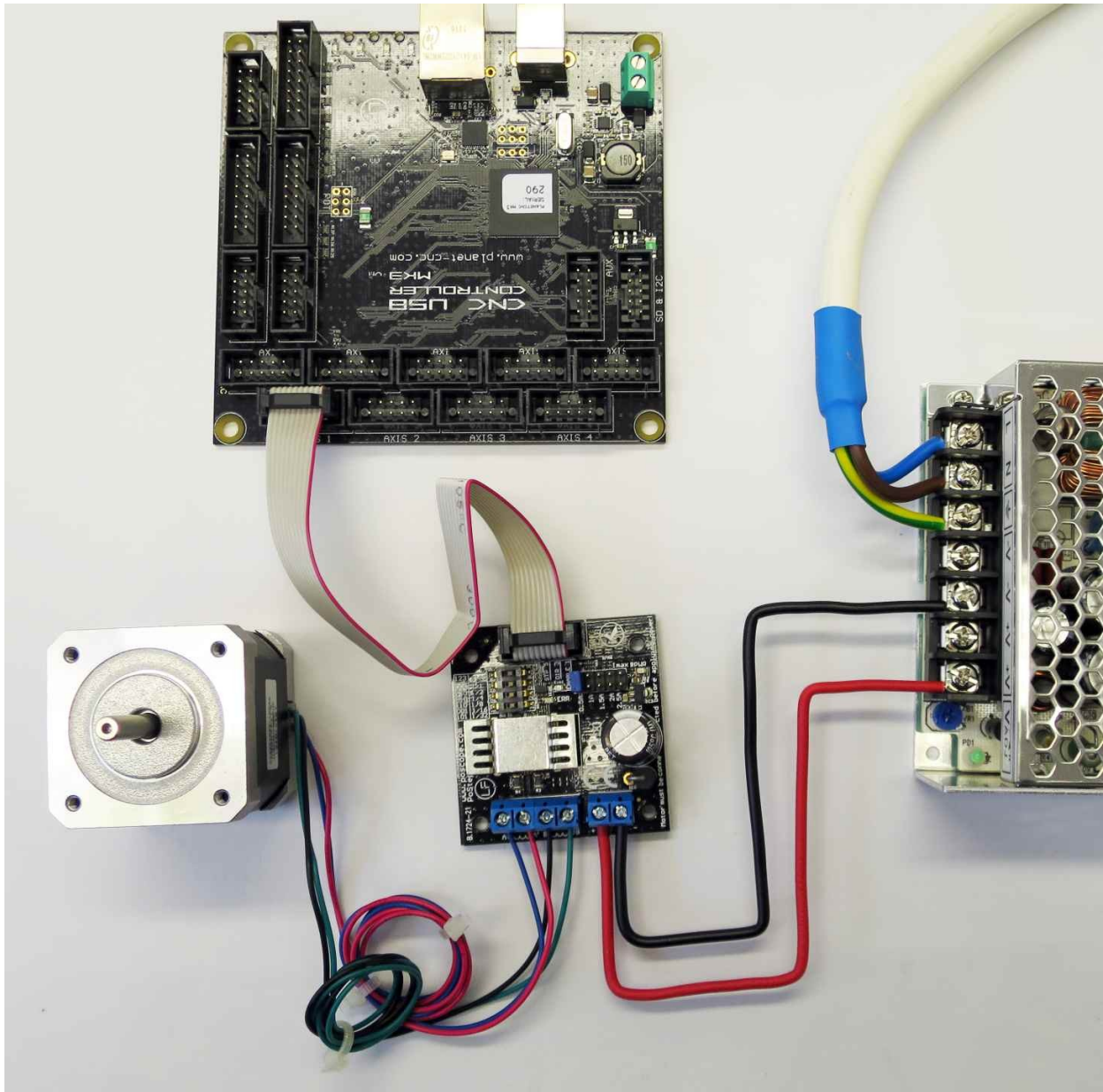

3.4 Shielded cables

We always recommend the use of shielded cables for wiring. Whether you are connecting limit switches, input switches, output devices, motor drivers or motors etc... The shielded cables should be properly maintained and set with insulated ferrules or crimp terminals.

Picture bellow demonstrates both ends of one shielded cable. Shield and GND are connected with ferrule only at that end of the cable which will be later connected to controllers input. Other end of the cable which will be connected to limit switch, does not have shield and GND connected.

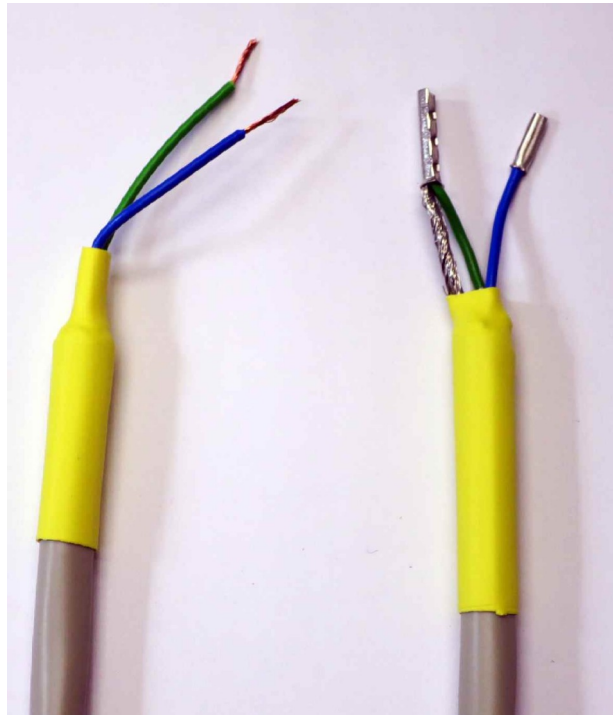

Shield of the cable should be connected to GND only at the end which is connected to controllers input:

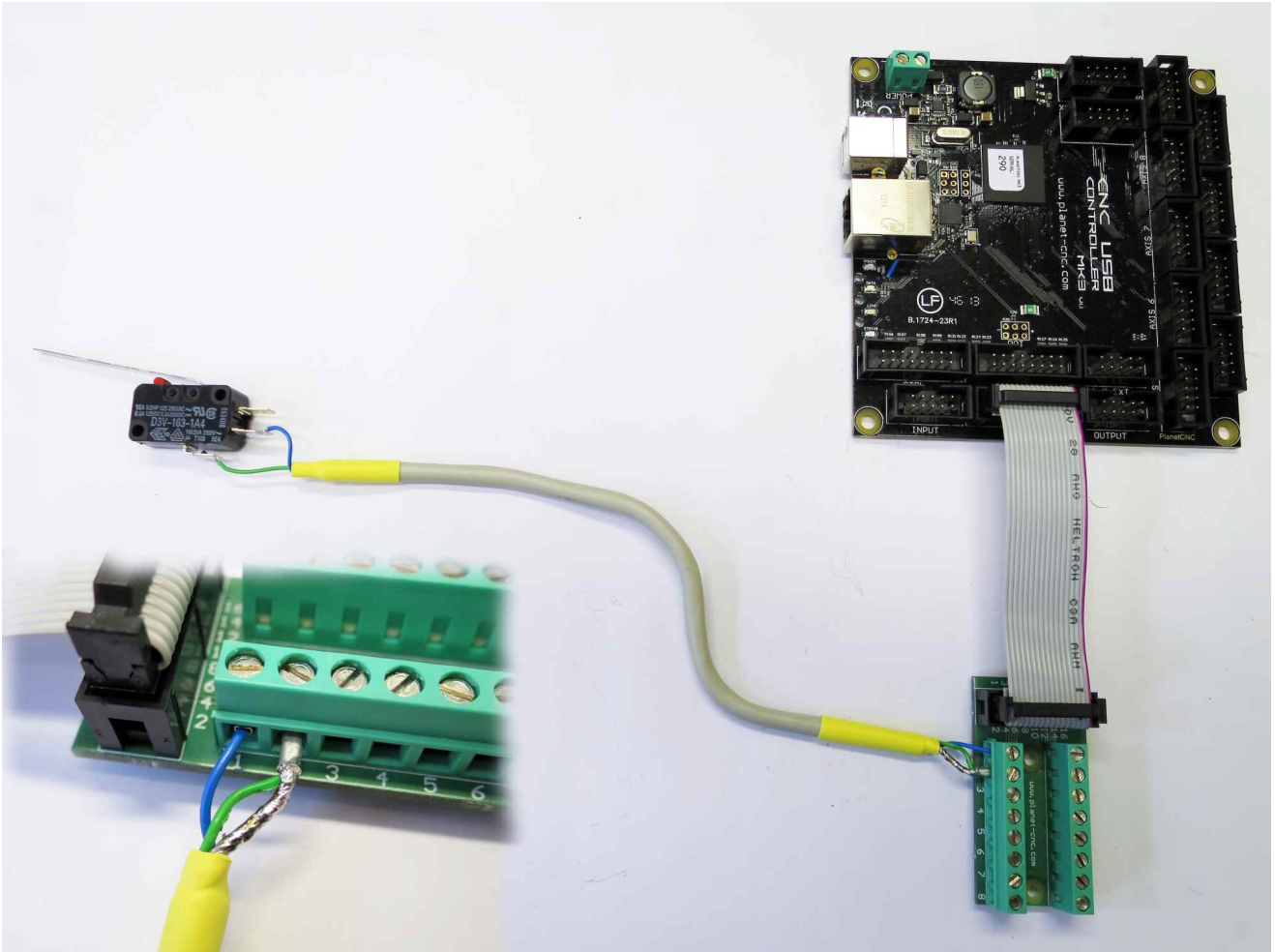

Table of Contents

1	Introduction.....	3
1.1	Overview.....	3
1.2	Features and specifications:.....	4
1.2.1	PlanetCNC TNG motion control software.....	4
1.2.2	Mk3 - 9 axes USB CNC controller.....	6
1.3	System Requirements.....	7
2	Hardware.....	8
2.1	Installation.....	8
2.2	Mk3 - 9 axis CNC USB controller description.....	9
2.2.1	Mk3 <i>AXIS</i> connector.....	10
2.2.2	Mk3 <i>JOG</i> connector.....	11
2.2.3	Mk3 <i>LIMIT</i> connector.....	12
2.2.4	Mk3 <i>CTRL</i> connector.....	14
2.2.5	Mk3 <i>INPUT</i> connector.....	16
2.2.6	Mk3 <i>OUTPUT</i> connector.....	17
2.2.7	Mk3 <i>EXT1</i> connector.....	18
2.2.8	Mk3 <i>EXT2</i> connector.....	19
2.2.9	Mk3 <i>CAN</i> connector.....	20
2.2.10	Mk3 <i>AUX</i> connector.....	21
2.2.11	Mk3 <i>POT</i> connector.....	22
2.2.12	Mk3 <i>USB</i> connector.....	23
2.2.13	Mk3 <i>Ethernet</i> connector.....	23
2.2.14	Mk3 <i>Power</i> terminal.....	23
2.2.15	Mk3 <i>LED</i> indicators.....	23
3	Connection diagrams.....	24
3.1	Wiring of limit switches.....	24
3.1.1	'Normal' wiring method.....	25
3.1.2	'Single input' wiring method.....	27
3.1.2.1	Parallel wiring of NO type switches:.....	27
3.1.2.2	Serial wiring of NC type limit switches:.....	29
3.2	Wiring inputs of Mk3 controller.....	31
3.3	Connecting motor driver to Mk3 controller.....	33
3.4	Shielded cables.....	36

